

NOTES:

1. FORM NEW CURB AND GUTTER SO THAT CONTROL JOINTS LINE UP ACROSS STREET.
2. SAW CUTS MUST BE ALIGNED W/CURB AND GUTTER CONTROL JOINTS.
3. SAW CUTS MUST BE MADE FOR ALL MH AND GV CASTINGS.

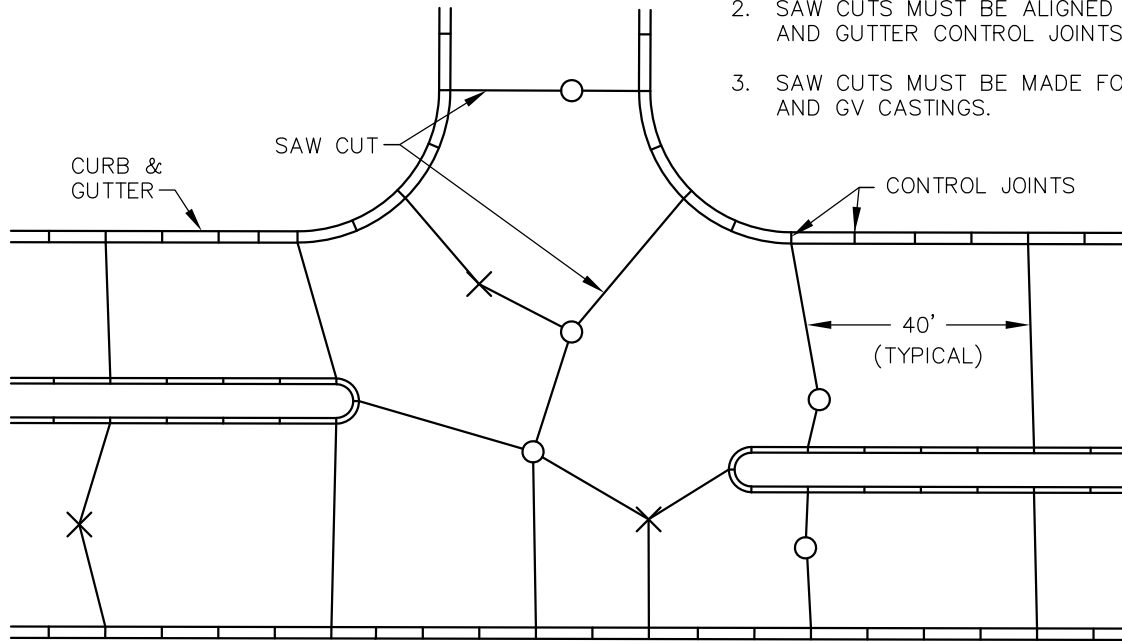

TYPICAL SAW AND SEAL JOINT LAYOUT

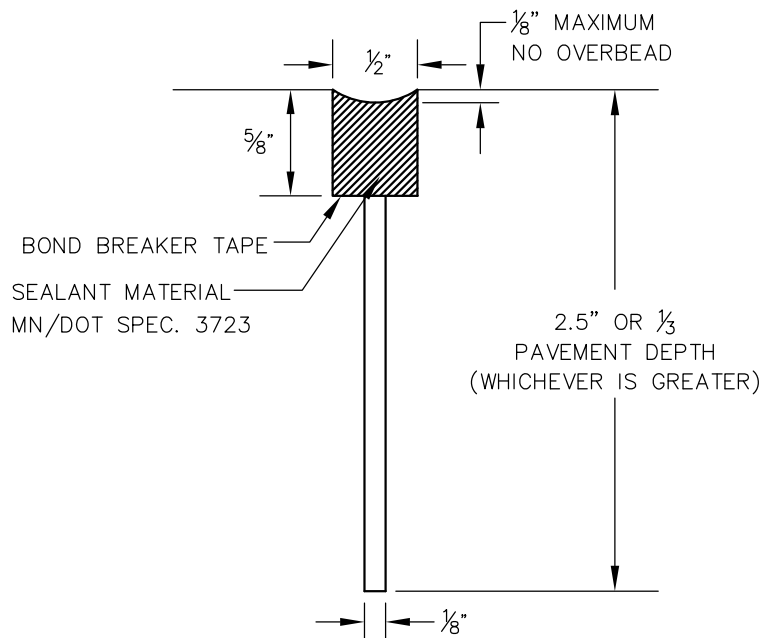

TYPICAL SAW AND SEAL JOINT