

157.5° SEAM
 180°
 90° 270°
 0°

M15S HH
 590C7-39 SS OCTAGON POLE CAP

(B) "C" LUMINAIRE
 MTG
 ("D" DEG FROM DOOR)

1/8"

"E"
 NOMINAL
 MTG HT

.0721 X 8.15 X 3.26 X "E"
 (24 3/4 + 9 3/4 = 34 1/2
 COIL)

"A" POLE WELDMENT

- (1) "F" SHAFT
- (1) 410A98-24 BASE PLATE
- (A) "C" LUM MTG PLT
- (1) 40B221-4 HH FRAME
- (1) 3/8-16NC X 3/4 LG HX HD BOLT (F593C-SS)
- (2) 3/8 BRASS FLATWASHER

M15S (3 X 5) HANDHOLE
 PER 40B221

12"

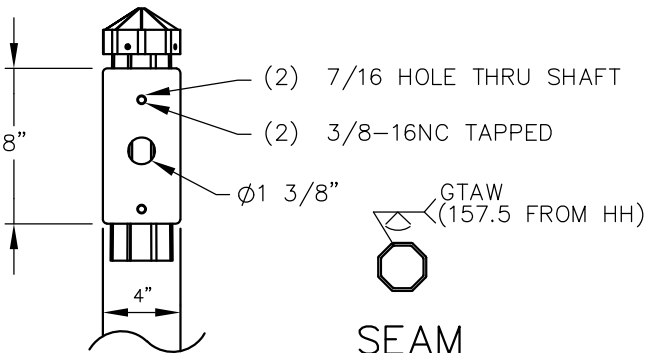
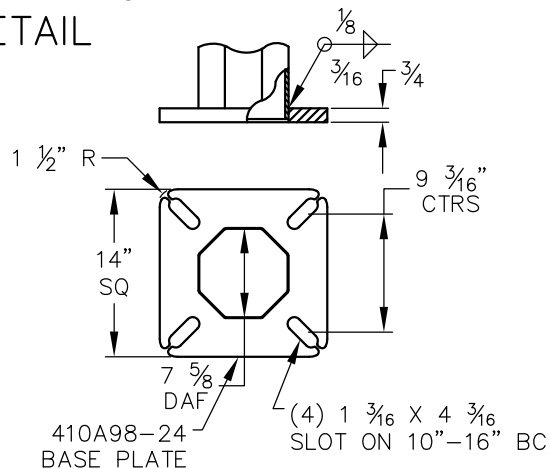

PLATE MTG
 DETAIL

SEAM
 WELD



POLE BASE
 DETAIL

NOTE:

1. POLE IS MANUFACTURED BY MILLERBERND.
2. MATERIAL- STAINLESS STEEL ASTM A240 (TYPE 201L) 50,000 PSI MIN YIELD AFTER MILL PROCESSING. BASE PLATE (TYPE 304L) 25,000 PSI MIN YIELD
3. THE POLE AND THE FOLLOWING PARTS ARE SHIPPED UNASSEMBLED:
 - (1) 40B221-1 M15 HH COVER
 - (1) 500B43-2 M15 HH LATCH
 - (1) 5/16-18NC X 2" LG HX SCKT FL HD SCREW (18-8 SS)
 - (1) 590C7-39 SS OCTAGON POLE CAP
4. PAINTED BLACK SEMI GLOSS:
 PT-1-17-FTU-017

40B1458		40B1458SW1	1	SKA711	270°	25'	SH8-.0721-081503263000	8-STA3-250-1FS711-002
DRAWING REF NO	QTY	"A" POLE WELDMENT	"B" QTY	"C" LUM MTG PLATE	"D" DEG FROM DOOR	"E" SHAFT HT	"F" SHAFT PART NO	PART NO